



Brief paper

Robust cooperative control of multiple heterogeneous Negative-Imaginary systems[☆]



Jianan Wang^{a,1}, Alexander Lanzon^b, Ian R. Petersen^c

^a Key Laboratory of Dynamics and Control of Flight Vehicle within Ministry of Education, School of Aerospace Engineering, Beijing Institute of Technology, Beijing 100081, China

^b Control Systems Centre, School of Electrical and Electronic Engineering, University of Manchester, Manchester M13 9PL, UK

^c School of Information Technology and Electrical Engineering, University of New South Wales, Australian Defence Force Academy, Canberra, A.C.T. 2600, Australia

ARTICLE INFO

Article history:

Received 8 November 2014

Received in revised form

11 April 2015

Accepted 12 July 2015

Keywords:

Cooperative control

Consensus

Robust control

Heterogeneous systems

Negative-Imaginary systems

ABSTRACT

This paper presents a consensus-based robust cooperative control framework for a wide class of linear time-invariant (LTI) systems, namely Negative-Imaginary (NI) systems. Output feedback, dynamic, Strictly Negative-Imaginary (SNI) controllers are applied in positive feedback to heterogeneous multi-input–multi-output (MIMO) plants through the network topology to achieve robust output feedback consensus. Robustness to external disturbances and model uncertainty is guaranteed via NI system theory. Cooperative tracking control of networked NI systems is presented as a corollary of the derived results by adapting the proposed consensus algorithm. Numerical examples are also given to demonstrate the effectiveness of proposed robust cooperative control framework.

© 2015 Elsevier Ltd. All rights reserved.

1. Introduction

Cooperative control of heterogeneous LTI systems has been widely studied in the literature and there is now a wealth of methods to handle different aspects of the nominal cooperative control problem. Robust cooperative control is however less studied due to the inherent complexities associated with robustness. For example, Cai and Hagen (2010) studies a cooperative control problem for a string of coupled heterogeneous subsystems. Such systems can arise in vehicle platoons. However, the systems considered are constrained to SISO systems (due to the mathematics of the continued fractions used) and do not allow poles on the imaginary axis, and also the graph is only restricted to string connections. On the other hand, Su and Huang (2013) solves a cooperative robust output regulation problem for a class of LTI systems with minimum phase dynamics. A combination of simultaneous high-gain state feedback

control and a distributed high-gain observer is adopted to achieve cooperative output regulation under particular parameter uncertainty as well as particular external disturbances. From a different perspective, Zhu and Chen (2014) discusses a full-state feedback robust consensus protocol for heterogeneous second-order multi-agent systems. Existing published literature on robust cooperative control of heterogeneous multi-agent systems is hence restricted to either only SISO plants, or minimum phase LTI plants or full-state feedback second order plants.

NI systems theory has drawn much attention (e.g. Ferrante & Ntogramatzidis, 2013, Opmeer, 2011 and Wang, Lanzon, & Petersen, in press) since it was introduced in Lanzon and Petersen (2008). This is because there are a wide class of LTI systems with negative imaginary frequency response, for which applications can be easily found in a variety of fields including aerospace, large space structures, multi-link robotic arms usually with co-located position sensors and force actuators (Petersen & Lanzon, 2010) and nano-positioning (Mabrok, Kallapur, Petersen, & Lanzon, 2014b), etc. Also the NI systems class is invariant to additive NI model uncertainty and other type interconnections as discussed in Ferrante, Lanzon, and Ntogramatzidis (submitted for publication). Thus, result based on NI systems theory immediately yield robustness to spill-over dynamics (Lanzon & Petersen, 2008; Petersen & Lanzon, 2010; Song, Lanzon, Patra, & Petersen, 2012a).

[☆] The material in this paper was not presented at any conference. This paper was recommended for publication in revised form by Associate Editor Tong Zhou under the direction of Editor Richard Middleton.

E-mail addresses: wangjianan@ieee.org (J.N. Wang), alexander.lanzon@manchester.ac.uk (A. Lanzon), i.r.petersen@gmail.com (I.R. Petersen).

¹ Tel.: +86 1068911921.

Nomenclature

I_n	$n \times n$ identity matrix
$\mathbf{1}_n$	$n \times 1$ vector with all elements being 1
$M > (\geq) 0$	M is a positive (semi-) definite matrix
$M < (\leq) 0$	M is a negative (semi-) definite matrix
$\text{Ker}(M)$	Kernel of a matrix M
$\text{Im}(M)$	Image of a matrix M
$\text{rank}(M)$	Rank of a matrix M
$\lambda_i(M), \lambda(M)$	The i th, largest eigenvalue of M
$\lambda(M), \det(M)$	Spectrum, determinant of matrix M
M^T	Transpose of matrix M
M^*	Complex conjugate transpose of matrix M
$\mathbb{R}^{m \times n}, \mathbb{C}^{m \times n}$	Set of $m \times n$ real, complex matrices
$\text{Re}[s]$	Real part of $s \in \mathbb{C}$
\mathcal{L}_2	Abbreviation for $\mathcal{L}_2[0, \infty)$
$\text{Im}_{\mathcal{L}_2}(G)$	Image of system $G(s)$ under all \mathcal{L}_2 inputs
\mathcal{RH}_∞	Set of real-rational stable transfer functions
$[P(s), P_s(s)]$	Positive feedback interconnection of 2 plants

A square, real, rational, proper transfer function matrix $P(s)$ is NI if the following conditions are satisfied (Lanzon & Petersen, 2008; Mabrok, Kallapur, Petersen, & Lanzon, 2014a; Xiong, Petersen, & Lanzon, 2010): (1) $P(s)$ has no pole in $\text{Re}[s] > 0$; (2) $\forall \omega > 0$ such that $j\omega$ is not a pole of $P(s)$, $j(P(j\omega) - P(j\omega)^*) \geq 0$; (3) If $s = j\omega_0$ where $\omega_0 > 0$ is a pole of $P(s)$, then it is a simple pole and the residue matrix $K = \lim_{s \rightarrow j\omega_0} (s - j\omega_0)jP(s)$ is Hermitian and positive semi-definite; (4) If $s = 0$ is a pole of $P(s)$, then $\lim_{s \rightarrow 0} s^k P(s) = 0 \forall k \geq 3$ and $P_2 = \lim_{s \rightarrow 0} s^2 P(s)$ is Hermitian and positive semi-definite. This definition includes free body dynamics which leads to dynamical models with poles at the origin, such as $\frac{s^2+1}{s^2(s^2+2)}$. Examples of NI systems can be found in Mabrok et al. (2014a), Petersen and Lanzon (2010), and these include a single-integrator system, a double-integrator system, second-order systems such as those that arise in undamped and damped flexible structures or inertial systems, to name a few typically considered in the consensus literature. Cooperative control of multiple NI systems arises with the development of NI systems' applications where one single NI system is incapable of achieving the mission goals, for example, the load is too heavy to be carried by one multi-link robotic arm.

This paper solves the general problem, robust output feedback cooperative control of heterogeneous MIMO NI systems (possibly with poles on the imaginary axis) under external disturbances and model uncertainty. Unlike the literature, we impose no minimum phase assumption; the communication graph can be any general undirected and connected graph rather than any specific graph; we allow MIMO agents; we consider explicitly robustness to both unmodelled dynamics of arbitrary order and energy-bounded disturbances; we handle output feedback rather than full state feedback; and explicitly characterise a family of control laws that could be tuned for performance. Towards this end, NI system theory is adopted to first derive conditions for robust output feedback consensus and then transport the proposed results to cooperative tracking to obtain a robust output feedback cooperative control framework for a wide class of LTI systems.

Preliminaries of graph theory: $\mathcal{G} = (\mathcal{V}, \mathcal{E})$ where $\mathcal{V} = \{v_1, v_2, \dots, v_n\}$ and $\mathcal{E} \subseteq \mathcal{V} \times \mathcal{V}$ mathematically describes a graph with n nodes and l edges. An undirected and connected graph requires that there exists at least one bidirectional path in \mathcal{E} connecting all nodes in \mathcal{V} . The incidence matrix \mathcal{Q} of \mathcal{G} is a $|\mathcal{V}| \times |\mathcal{E}|$ ($n \times l$) matrix, which can be attained by first letting each edge in the graph have an arbitrary but fixed orientation and then

$$\mathcal{Q} := \begin{cases} q_{ve} = 1 & \text{if } v \text{ is the initial vertex of edge } e, \\ q_{ve} = -1 & \text{if } v \text{ is the terminal vertex of edge } e, \\ q_{ve} = 0 & \text{if } v \text{ is not connected to } e. \end{cases}$$

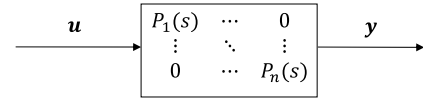

Fig. 1. Multiple heterogeneous NI plants.

For an undirected graph \mathcal{G} , \mathcal{Q} is not unique but the corresponding Laplacian matrix is unique and given by $\mathcal{L}_n = \mathcal{Q}\mathcal{Q}^T$. Similarly, the edge-weighted Laplacian is also unique given by $\mathcal{L}_e = \mathcal{Q}\mathcal{K}\mathcal{Q}^T$, where $\mathcal{K} \geq 0$ is the diagonal edge weighting matrix. It is also shown in Bapat (2010) that $\text{rank}(\mathcal{Q}) = n - 1 = \text{rank}(\mathcal{L}_n)$ when \mathcal{G} is connected and $\text{rank}(\mathcal{Q}) = n - 1 = \text{rank}(\mathcal{L}_e)$ when \mathcal{G} is connected and $\det(\mathcal{K}) \neq 0$. It is well-known (Ren & Beard, 2008) that \mathcal{L}_n and \mathcal{L}_e will both have one unique zero eigenvalue associated with the eigenvector $\mathbf{1}_n$ and all the other eigenvalues are positive and real, when $\det(\mathcal{K}) \neq 0$, \mathcal{G} is undirected and connected. In this case, $\mathcal{L}_n \geq 0, \mathcal{L}_e \geq 0$, and

$$\text{Ker}(\mathcal{L}_n) = \text{Ker}(\mathcal{L}_e) = \text{Ker}(\mathcal{Q}^T) = \text{span}\{\mathbf{1}_n\}. \quad (1)$$

Note also that, for an undirected and connected graph \mathcal{G} , any row removal of \mathcal{Q} or column removal of \mathcal{Q}^T yields a full row rank \mathcal{Q} or a full column rank \mathcal{Q}^T respectively by inspecting the relation of Laplacian matrix with \mathcal{Q} and the property of positive semi-definite matrices with a kernel dimension of 1 (Golub & Van Loan, 2012).

2. Robust output feedback consensus

In this section, we will consider robust output feedback consensus for multiple heterogeneous NI systems under \mathcal{L}_2 external disturbance and additive SNI model uncertainty (as would arise in spill-over dynamics for truncated order flexible structures). Two cases will be discussed to cover all the heterogeneous cases. First of all, let us begin with the problem formulation with the following notation: $\max_{i=1}^n \{a_i\}$ is the maximum value of $a_i, i \in \{1, \dots, n\}$ and $\text{diag}\{A_i\}$ is a block-diagonal matrix with $A_i, i \in \{1, \dots, n\}$ on the diagonal. A square, real, rational, proper transfer function matrix $P_s(s)$ is SNI if the following conditions are satisfied: (1) $P_s(s)$ has no pole in $\text{Re}[s] \geq 0$; (2) $\forall \omega > 0, j(P_s(j\omega) - P_s(j\omega)^*) > 0$. Examples of SNI systems include $\frac{1}{s+a}$ where $a > 0, \frac{a}{s^2+bs+c}$ where $a, b, c > 0$ or non-minimum phase systems such as $\frac{1-s}{2+s}$. See Lanzon and Petersen (2008), Petersen and Lanzon (2010) for further examples.

For multiple heterogeneous NI systems (in general MIMO) with $n > 1$ agents, the transfer function of agent $i \in \{1, \dots, n\}$ is given as

$$\hat{y}_i = \hat{P}_i(s)\hat{u}_i, \quad (2)$$

where $\hat{y}_i \in \mathbb{R}^{m_i \times 1}$ and $\hat{u}_i \in \mathbb{R}^{m_i \times 1}$ are the output and input of agent i respectively. In order to deal with the consensus of different dimensional inputs/outputs, $\hat{P}_i(s)$ can be padded with zeros up to $m = \max_{i=1}^n \{m_i\}$ and the locations of padding zeros depend on which output needs to be coordinated, for instance, $P_i(s) = \begin{bmatrix} \hat{P}_i(s) & 0 \\ 0 & 0 \end{bmatrix}$ has dimension of m such that the first m_i outputs are to be coordinated, or $P_i(s) = \begin{bmatrix} 0 & 0 \\ 0 & \hat{P}_i(s) \end{bmatrix}$ also has dimension of m , but now the last m_i outputs are to be coordinated instead. Accordingly, the input \hat{u}_i and output \hat{y}_i are extended to be $u_i = [\hat{u}_i^T \ 0]^T$ or $[0 \ \hat{u}_i^T]^T \in \mathbb{R}^{m \times 1}$, and $y_i = [\hat{y}_i^T \ 0]^T$ or $[0 \ \hat{y}_i^T]^T \in \mathbb{R}^{m \times 1}$, respectively. Note that interleaving zero rows and corresponding columns within $\hat{P}_i(s)$ is also permissible. It can be easily seen that the above manipulation would preserve the NI property by checking the definition. Therefore, without loss of generality, the overall plant can be described as Fig. 1:

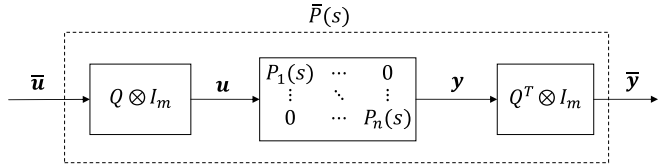

Fig. 2. Overall network plant.

where $\mathbf{y} = [\mathbf{y}_1^T, \dots, \mathbf{y}_n^T]^T \in \mathbb{R}^{nm \times 1}$ and $\mathbf{u} = [\mathbf{u}_1^T, \dots, \mathbf{u}_n^T]^T \in \mathbb{R}^{nm \times 1}$. We now define robust output feedback consensus as follows:

Definition 1. A distributed output feedback control law achieves robust output feedback consensus for a network of systems if for a family of plant dynamics and for all $\mathcal{L}_2[0, \infty)$ disturbances on the plant input and/or plant output, $\mathbf{y}_i - \mathbf{y}_{ss} \in \mathcal{L}_2[0, \infty) \forall i \in \{1, \dots, n\}$. Here \mathbf{y}_{ss} is the final convergence trajectory, which can be a function of time depending on the plant and controller dynamics.

Remark 2. Note that since transfer functions in \mathcal{RH}_∞ map $\mathcal{L}_2[0, \infty)$ to $\mathcal{L}_2[0, \infty)$ and due to the superposition theorem of linear systems (Zhou, Doyle, & Glover, 1996), if there are no disturbances, then $\mathbf{y}_i - \mathbf{y}_{ss} \rightarrow \mathbf{0} \forall i \in \{1, \dots, n\}$ in Definition 1 retrieving the typical consensus meaning in the literature.

Observe that if one were to construct the overall networked plant dynamics involving the heterogeneous multiple agents $P_i(s)$ and the communications graph represented by a Laplacian matrix \mathcal{L}_n as $(\mathcal{L}_n \otimes I_m) \cdot \text{diag}\{P_i(s)\}$, then the overall networked plant is not NI any more due to asymmetry despite each heterogeneous agent being individually NI. This would then make NI systems theory inapplicable. Instead, we can utilise the incidence matrix \mathcal{Q} instead of \mathcal{L}_n to reformulate the overall networked plant as shown in Fig. 2:

The reason for adopting the incidence matrix \mathcal{Q} before and after the plant dynamics instead of a Laplacian matrix $\mathcal{L}_n = \mathcal{Q}\mathcal{Q}^T$ totally before or after the plant dynamics is to guarantee that the resultant controller is distributed and only uses local information. This will be explained in more detail later in this section. The augmented system can be derived as

$$\bar{\mathbf{y}} = \bar{P}(s)\bar{\mathbf{u}} = (\mathcal{Q}^T \otimes I_m) \text{diag}\{P_i(s)\} (\mathcal{Q} \otimes I_m) \bar{\mathbf{u}} \quad (3)$$

where $\bar{\mathbf{y}} = [\bar{\mathbf{y}}_1^T, \dots, \bar{\mathbf{y}}_l^T]^T \in \mathbb{R}^{lm \times 1}$ and $\bar{\mathbf{u}} = [\bar{\mathbf{u}}_1^T, \dots, \bar{\mathbf{u}}_l^T]^T \in \mathbb{R}^{lm \times 1}$ are the output and input vectors for the overall system. It can be concluded that the overall system $\bar{P}(s)$ is still NI due to the following lemmas:

Lemma 3. $\text{diag}\{P_i(s)\}$ is NI if and only if $P_i(s)$ are all NI $\forall i \in \{1, \dots, n\}$.

The proof of Lemma 3 is straightforward from the definition of NI systems. The same argument also applies for SNI functions. The following lemma which is also straightforward from the definition of NI systems allows further manipulation.

Lemma 4. Given any NI MIMO $P(s)$, then $\bar{P}(s) = FP(s)F^*$ is NI for any constant matrix F .

The output $\mathbf{y} \in \mathbb{R}^{nm \times 1}$ reaches consensus (i.e. $\mathbf{y}_i = \mathbf{y}_j \forall i, j$) when $\bar{\mathbf{y}} \rightarrow \mathbf{0} \in \mathbb{R}^{lm \times 1}$ by noticing the properties of the incidence matrix \mathcal{Q} given in (1). This formulation converts the output consensus problem to an equivalent internal stability problem. Then robustness properties can be studied via standard control theoretic methods to yield robust consensus results. We now impose the following assumptions throughout the rest of this paper:

Assumption 5. \mathcal{G} is undirected and connected.

Assumption 6. Let $\Delta_i(s) \forall i \in \{1, \dots, n\}$ be arbitrary SNI systems satisfying $\bar{\lambda}(\Delta_i(0)) < \mu$, $\Delta_i(\infty) = 0 \forall i \in \{1, \dots, n\}$, and $0 < \mu \in \mathbb{R}$.

In the sequel, robust output feedback consensus will be discussed along two directions: NI plants without or with free body dynamics to cover all the heterogeneous types of NI systems.

2.1. NI plants without free body dynamics

In this subsection, NI plants without free body dynamics will be first considered, which also means $\hat{P}_i(s)$ has no poles at the origin. The following lemmas are needed:

Lemma 7 (Golub & Van Loan, 2012). Given $M \in \mathbb{R}^{n \times m}$, $\bar{\lambda}(MM^T) = \bar{\lambda}(M^T M)$.

Lemma 8. Assume M is Hermitian with $\bar{\lambda}(M) \geq 0$ and $N \geq 0$, we have $\bar{\lambda}(MN) \leq \bar{\lambda}(M)\bar{\lambda}(N)$.

Proof. Since $M \leq \bar{\lambda}(M)I$, we obtain $N^{\frac{1}{2}}MN^{\frac{1}{2}} \leq \bar{\lambda}(M)N$. With the condition of $\bar{\lambda}(M) \geq 0$, $N^{\frac{1}{2}}MN^{\frac{1}{2}} \leq \bar{\lambda}(M)N \leq \bar{\lambda}(M)\bar{\lambda}(N)I$. Thus, $\bar{\lambda}(MN) = \bar{\lambda}(N^{\frac{1}{2}}MN^{\frac{1}{2}}) \leq \bar{\lambda}(M)\bar{\lambda}(N)$. \square

Lemma 9 (Lanzon & Petersen, 2008; Xiong et al., 2010). Given an NI transfer function $P(s)$ and an SNI function $P_s(s)$ with $P(s)$ having no pole(s) at the origin, $P(\infty)P_s(\infty) = 0$ and $P_s(\infty) \geq 0$. $[P(s), P_s(s)]$ is internally stable if and only if $\bar{\lambda}(P(0)P_s(0)) < 1$.

Next we present the first main result of this paper with the definition of $\bar{P}_s(s) = \text{diag}\{P_{s,j}(s)\}$ where $P_{s,j}(s)$ are arbitrary SNI compensators.

Theorem 10. Given a graph \mathcal{G} with incidence matrix \mathcal{Q} , satisfying Assumption 5 and modelling the communication links among multiple NI agents $\hat{P}_i(s)$ with no pole(s) at the origin which are appropriately padded with rows and columns of zeros to give $P_i(s)$ in Fig. 3. Robust output feedback consensus is achieved via the output feedback control law

$$\mathbf{u} = (\mathcal{Q} \otimes I_m) \bar{P}_s(s) (\mathcal{Q}^T \otimes I_m) \mathbf{y} \quad (4)$$

(or in a distributed manner for agent i via

$$\mathbf{u}_i = \sum_{k=1}^n a_{ik} P_{s,j}(s) (\mathbf{y}_i - \mathbf{y}_k), \quad (5)$$

where a_{ik} are the elements of the adjacency matrix² and j is the edge connecting vertex i to vertex k) under any external disturbances $w_1 \in \text{Im}_{\mathcal{L}_2}(\mathcal{Q} \otimes I_m)$ and $w_2 \in \mathcal{L}_2$ if $\exists i \in \{1, \dots, n\} : \bar{\lambda}(P_i(0)) \geq 0$ and $\forall i \in \{1, \dots, n\}, j \in \{1, \dots, l\}$ all the following conditions hold:

$$\bar{\lambda}(P_i(0)) \bar{\lambda}(P_{s,j}(0)) < \frac{1}{\bar{\lambda}(\mathcal{L}_n)}, \quad (6)$$

$P_i(\infty)P_{s,j}(\infty) = 0$ (where i is the vertex of edge j) and $P_{s,j}(\infty) \geq 0$. The output feedback consensus control law (4) will be robust to all model uncertainty $\Delta_i(s), i \in \{1, \dots, n\}$ satisfying Assumption 6 if the D.C. gain of the SNI compensator $P_s(s)$ is tuned more stringently such that $\forall i \in \{1, \dots, n\}, j \in \{1, \dots, l\}$

$$\bar{\lambda}(P_i(0)) + \mu < \frac{1}{\bar{\lambda}(\mathcal{L}_n) \bar{\lambda}(P_{s,j}(0))}. \quad (7)$$

² See Ren and Beard (2008) for definition.

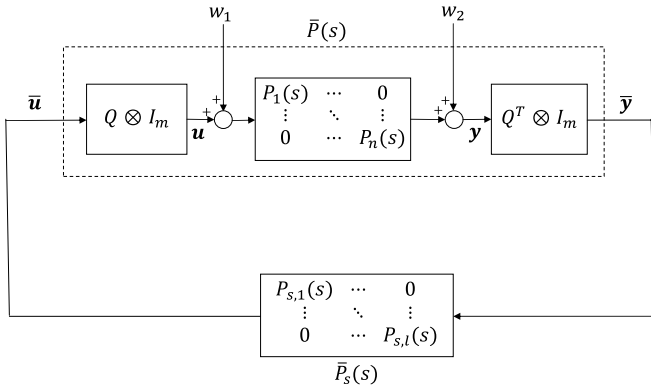

Fig. 3. Positive feedback interconnection with SNI compensators through the network topology.

Proof. From Fig. 3, Lemmas 3 and 4, it can be seen that $\bar{P}(s)$ is NI without pole(s) at the origin and $\bar{P}_s(s)$ is SNI. Applying Lemma 8, we obtain

$$\begin{aligned} & \bar{\lambda}(\bar{P}(0)\bar{P}_s(0)) \\ &= \bar{\lambda}((\mathcal{Q}^T \otimes I_m) \text{diag}\{P_i(0)\}(\mathcal{Q} \otimes I_m) \text{diag}\{P_{s,j}(0)\}) \\ &\leq \bar{\lambda}((\mathcal{Q}^T \otimes I_m) \text{diag}\{P_i(0)\}(\mathcal{Q} \otimes I_m)) \max_{j=1}^l \{\bar{\lambda}(P_{s,j}(0))\} \\ &\leq \max_{i=1}^n \{\bar{\lambda}(P_i(0))\} \bar{\lambda}(\mathcal{Q}^T \mathcal{Q}) \max_{j=1}^l \{\bar{\lambda}(P_{s,j}(0))\} \\ &\quad (\text{since } \exists i : \bar{\lambda}(P_i(0)) \geq 0) \\ &= \max_{i=1}^n \{\bar{\lambda}(P_i(0))\} \max_{j=1}^l \{\bar{\lambda}(P_{s,j}(0))\} \bar{\lambda}(\mathcal{L}_n) \quad (\text{by Lemma 7}) \end{aligned}$$

since $\bar{\lambda}(\bar{P}(0)) \geq 0$ (because $\exists i : \bar{\lambda}(P_i(0)) \geq 0$) and $P_{s,j}(0) > P_{s,j}(\infty) \geq 0 \forall j \in \{1, \dots, l\}$ (due to Lemma 2 in Lanzon and Petersen (2008) with the assumption of $P_{s,j}(\infty) \geq 0$). Thus, since $\exists i \in \{1, \dots, n\} : \bar{\lambda}(P_i(0)) \geq 0$ and $\forall i = 1, \dots, n$ and $j = 1, \dots, l$, all of the following hold: $\bar{\lambda}(P_i(0))\bar{\lambda}(P_{s,j}(0)) < \frac{1}{\bar{\lambda}(\mathcal{L}_n)}$, $P_i(\infty)P_{s,j}(\infty) = 0$ (where i is the vertex of edge j) and $P_{s,j}(\infty) \geq 0$, $[\bar{P}(s), \bar{P}_s(s)]$ is internally stable via NI systems theory in Lemma 9. This then implies nominal output consensus when the disturbances w_1 and w_2 are set to zero by noting that $\bar{y} \rightarrow 0 \Leftrightarrow y - \mathbf{1}_n \otimes y_{ss} \rightarrow 0$, i.e., $y_i - y_{ss} \rightarrow 0$ since the graph \mathcal{G} is undirected and connected.

In addition, internal stability of $[\bar{P}(s), \bar{P}_s(s)]$ and superposition principle of linear systems (Zhou et al., 1996) guarantee that $y_i \rightarrow y_{ss} + \delta$ with $\delta \in \mathcal{L}_2$ for all \mathcal{L}_2 exogenous signal injections perturbing signals \bar{u} and \bar{y} , which in turn means that any $w_1 \in \text{Im}_{\mathcal{L}_2}(\mathcal{Q} \otimes I_m)$ and any $w_2 \in \mathcal{L}_2$ can be injected in Fig. 3. Hence, the control protocol (4) will achieve a perturbed \mathcal{L}_2 consensus signal on output y (due to superposition principle of linear systems) for all disturbances $w_1 \in \text{Im}_{\mathcal{L}_2}(\mathcal{Q} \otimes I_m)$ and $w_2 \in \mathcal{L}_2$.

Additive model uncertainties $\Delta_i(s) \forall i \in \{1, \dots, n\}$ satisfying Assumption 6 can be dealt with as in Song et al. (2012a), which is shown in Fig. 4.

Fig. 4 (top) can be manipulated to Fig. 4 (bottom) with $M(s) = (\mathcal{Q} \otimes I_m)\bar{P}_s(s)(I - \bar{P}(s)\bar{P}_s(s))^{-1}(\mathcal{Q}^T \otimes I_m)$. Internal stability already yields $M(s) \in \mathcal{RH}_\infty$ and $M(s)$ is NI via Theorem 6 in Ferrante et al. (submitted for publication) in general, or via Theorem 6 in Petersen and Lanzon (2010) when $P_i(s)$ have no poles on the imaginary axis. This NI system $M(s)$ is connected with $\bar{\Delta}(s)$ which fulfills Assumption 6. Now

$$\begin{aligned} & \bar{\lambda}(\Delta(0)M(0)) \\ &\leq \bar{\lambda}(\Delta(0))\bar{\lambda}[(\mathcal{Q} \otimes I_m)\bar{P}_s(0)(I - \bar{P}(0)\bar{P}_s(0))^{-1}(\mathcal{Q}^T \otimes I_m)] \\ &\leq \mu\bar{\lambda}(\mathcal{L}_n)\bar{\lambda}[\bar{P}_s(0)(I - \bar{P}(0)\bar{P}_s(0))^{-1}] \end{aligned}$$

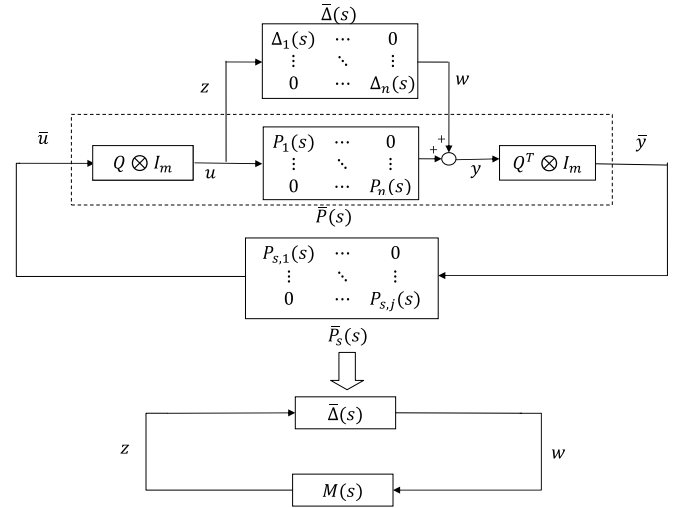

Fig. 4. Robustness to model uncertainty via NI system theory.

$$\begin{aligned} & \leq \frac{\mu\bar{\lambda}(\mathcal{L}_n)\bar{\lambda}(\bar{P}_s(0))}{1 - \bar{\lambda}(\bar{P}(0)\bar{P}_s(0))} \\ & \leq \frac{\mu\bar{\lambda}(\mathcal{L}_n) \max_{j=1}^l \{\bar{\lambda}(P_{s,j}(0))\}}{1 - \max_{i=1}^n \{\bar{\lambda}(P_i(0))\} \bar{\lambda}(\mathcal{L}_n) \max_{j=1}^l \{\bar{\lambda}(P_{s,j}(0))\}}. \end{aligned}$$

It is then clear that inequality (7) guarantees $\bar{\lambda}(\Delta(0)M(0)) < 1$ which in turn implies robust stability for all uncertainties that satisfy Assumption 6. \square

Remark 11. Inequality (6) only provides a sufficient condition due to the heterogeneity of systems. It also implies $\bar{\lambda}(P_i(0)P_{s,j}(0)) \leq \bar{\lambda}(P_i(0))\bar{\lambda}(P_{s,j}(0)) < \frac{1}{\bar{\lambda}(\mathcal{L}_n)}$ due to Lemma 8, which gives a more stringent condition than that of internal stability of $[P_i(s), P_{s,j}(s)]$, i.e., $\bar{\lambda}(P_i(0)P_{s,j}(0)) < 1$ (on noting that $\bar{\lambda}(\mathcal{L}_n) > 1$ due to Groné & Merris, 1994). This coincides with engineering intuition since the stability condition for networked systems is always more stringent than that of single agent system (Li, Duan, Chen, & Huang, 2010).

Remark 12. Since we assume that $\exists i : \bar{\lambda}(P_i(0)) \geq 0$ and since values of i such that $\bar{\lambda}(P_i(0)) \leq 0$ automatically fulfill inequality (6), only values of i such that $\bar{\lambda}(P_i(0)) > 0$ need to be checked. For values of i such that $\bar{\lambda}(P_i(0)) > 0$, the D.C. gain of the SNI controllers always need to be tuned for small eigenvalues in order to satisfy inequality (6). SNI control synthesis for robust performance is beyond the scope of this paper. Interested readers are referred to Song et al. (2012a) and Song, Lanzon, Patra, and Petersen (2012b).

Remark 13. There is clearly a huge class of permissible dynamic perturbations to the nominal dynamics as Assumption 6 only imposes a restriction on $\Delta_i(s)$ at the frequency $\omega = 0$ and $\omega = \infty$ and the SNI class has no gain (as long as it is finite gain) or order restriction (Lanzon & Petersen, 2008). The result in Theorem 10 is for additive perturbations, but similar analysis can be performed for other types of perturbations that preserve the NI class. A few examples of permissible perturbations that preserve the NI class include additive perturbations where uncertainty is also NI (Lanzon & Petersen, 2008), feedback perturbations where both systems in the feedback interconnection are NI (Petersen & Lanzon, 2010) and more general perturbations based Redheffer Star-products and Linear Fractional Transformations (Ferrante et al., submitted for publication). For example, $\frac{1}{s+5}$ and $\frac{(2s^2+s+1)}{(s^2+2s+5)(s+1)(2s+1)}$ are SNI with the same D.C. gain.

2.2. NI plants with free body dynamics

In this subsection, we will consider more general NI plants by including free body dynamics (i.e. poles at the origin) under the assumption of strict properness, i.e. $P_i(\infty) = 0$. Hence, this subsection covers the cases where the NI plant has poles at the origin. The NI class restricts the number of such poles at the origin to be at most 2. The following residue matrices carrying information about the properties of the free body motion for the NI system $\mathbf{y} = P(s)\mathbf{u}$ where $P(s) \in \mathbb{R}^{m \times m}$ (Mabrok et al., 2014a): $P_2 = \lim_{s \rightarrow 0} s^2 P(s)$, $P_1 = \lim_{s \rightarrow 0} s(P(s) - \frac{P_2}{s^2})$, $P_0 = \lim_{s \rightarrow 0} (P(s) - \frac{P_2}{s^2} - \frac{P_1}{s})$. It can be observed that $P_1 = 0$, $P_2 = 0$ means there is no free body dynamics, $P_1 \neq 0$, $P_2 = 0$ means there is free body dynamics with 1 pole at the origin, $P_2 \neq 0$ means there is free body dynamics with 2 poles at the origin. Then, we can define the Hankel matrix Γ as $\Gamma = \begin{bmatrix} P_1 & P_2 \\ P_2 & 0 \end{bmatrix} \in \mathbb{R}^{2m \times 2m}$, where $P_1, P_2 \in \mathbb{R}^{m \times m}$. In the subsection, we assume $\Gamma \neq 0$ since either $P_1 \neq 0$ or $P_2 \neq 0$. Then Γ can be decomposed by Singular Value Decomposition (SVD) as

$$\Gamma = [U_1 \quad U_2] \begin{bmatrix} S & 0 \\ 0 & 0 \end{bmatrix} \begin{bmatrix} V_1^T \\ V_2^T \end{bmatrix} = U_1 S V_1^T = H V_1^T = \begin{bmatrix} H_1 \\ H_2 \end{bmatrix} V_1^T,$$

where the diagonal matrix $S > 0$, the matrices $[U_1 \quad U_2]$ and $[V_1 \quad V_2]$ are orthogonal, $H = U_1 S \in \mathbb{R}^{2m \times \bar{n}}$, $H_1, H_2 \in \mathbb{R}^{m \times \bar{n}}$ and the matrices H and V_1 have orthogonal columns. Then, the matrix $H_1^T H_2$ can be further decomposed by SVD as $H_1^T H_2 = \hat{U} \hat{S} \hat{V}^T = \hat{U} \begin{bmatrix} S_1 & 0 \\ 0 & 0 \end{bmatrix} \begin{bmatrix} \hat{V}_1^T \\ \hat{V}_2^T \end{bmatrix}$, where $\hat{U}, \hat{V} = [\hat{V}_1 \quad \hat{V}_2]^T \in \mathbb{R}^{\bar{n} \times \bar{n}}$ are orthogonal matrices, $\hat{V}_2 \in \mathbb{R}^{\bar{n} \times \bar{n}}$ and the diagonal matrix $S_1 > 0$. Also, define $F = H_1 \hat{V}_2 \in \mathbb{R}^{m \times \bar{n}}$ and $N_f = P_s(0) - P_s(0)F(F^T P_s(0)F)^{-1} F^T P_s(0)$, where $P_s(s)$ is an SNI controller. When $P_2 \neq 0$, define $N_2 = P_s(0) - P_s(0)J(J^T P_s(0)J)^{-1} J^T P_s(0)$, where J is a full column rank matrix satisfying $JJ^T = P_2$. When $P_2 = 0$ and $P_1 \neq 0$, P_1 can be decomposed by SVD as $P_1 = [\tilde{U}_1 \quad \tilde{U}_2] \begin{bmatrix} S_2 & 0 \\ 0 & 0 \end{bmatrix} \begin{bmatrix} \tilde{V}_1^T \\ \tilde{V}_2^T \end{bmatrix} = F_1 V_1^T$, where $[\tilde{U}_1 \quad \tilde{U}_2]$ and $[V_1 \quad V_2]$ are orthogonal matrices, the diagonal matrix $S_2 > 0$ and F_1 and V_1 have orthogonal columns. Then, define $N_1 = P_s(0) - P_s(0)F_1(F_1^T P_s(0)F_1)^{-1} F_1^T P_s(0)$. Next, internal stability of $[P(s), P_s(s)]$ with free body dynamics can be summarised in the following lemma.

Lemma 14 (Mabrok et al., 2014a). Let $P(s)$ be a strictly proper NI plant and $P_s(s)$ be an SNI controller.

(1) Suppose $P_2 \neq 0$, N_f is sign definite and $F^T P_s(0)F$ is non-singular. Then, $[P(s), P_s(s)]$ is internally stable if and only if $F^T P_s(0)F < 0$ and either

$$I - N_f^{\frac{1}{2}} P_0 N_f^{\frac{1}{2}} - N_f^{\frac{1}{2}} P_1 J (J^T J)^{-2} J^T P_1^T N_f^{\frac{1}{2}} > 0 \quad (8)$$

when $N_f \geq 0$ or

$$\det(I + \tilde{N}_f P_0 \tilde{N}_f + \tilde{N}_f P_1 J (J^T J)^{-2} J^T P_1^T \tilde{N}_f) \neq 0 \quad (9)$$

when $N_f \leq 0$ where $\tilde{N}_f = (-N_f)^{\frac{1}{2}}$.

If furthermore $P_1 = 0$, N_2 is sign definite and $J^T P_s(0)J$ is non-singular, the necessary and sufficient conditions for the internal stability of $[P(s), P_s(s)]$ reduce to $J^T P_s(0)J < 0$ and either $I - N_2^{\frac{1}{2}} P_0 N_2^{\frac{1}{2}} > 0$ when $N_2 \geq 0$ or $\det(I + \tilde{N}_2 P_0 \tilde{N}_2) \neq 0$ when $N_2 \leq 0$ where $\tilde{N}_2 = (-N_2)^{\frac{1}{2}}$.

If additionally $\text{Ker}(P_2) \subseteq \text{Ker}(P_0^T)$, the necessary and sufficient condition for the internal stability of $[P(s), P_s(s)]$ reduces to $J^T P_s(0)J < 0$. When $P_2 > 0$, the necessary and sufficient condition for the internal stability of $[P(s), P_s(s)]$ reduces to $P_s(0) < 0$.

(2) Suppose $P_2 = 0$, $P_1 \neq 0$, N_1 is sign definite and $F_1^T P_s(0)F_1$ is non-singular. Then $[P(s), P_s(s)]$ is internally stable if and only if $F_1^T P_s(0)F_1 < 0$ and either $I - N_1^{\frac{1}{2}} P_0 N_1^{\frac{1}{2}} > 0$ when $N_1 \geq 0$ or $\det(I + \tilde{N}_1 P_0 \tilde{N}_1) \neq 0$ when $N_1 \leq 0$ where $\tilde{N}_1 = (-N_1)^{\frac{1}{2}}$.

If furthermore $\text{Ker}(P_1^T) \subseteq \text{Ker}(P_0^T)$, the necessary and sufficient condition for the internal stability of $[P(s), P_s(s)]$ reduces to $F_1^T P_s(0)F_1 < 0$. when P_1 is invertible, the necessary and sufficient condition for the internal stability of $[P(s), P_s(s)]$ reduces to $P_s(0) < 0$.

Next we present the second main result of this paper with the following notation: $\bar{P}_2 = \lim_{s \rightarrow 0} s^2 \bar{P}(s)$, $\bar{P}_1 = \lim_{s \rightarrow 0} s(\bar{P}(s) - \frac{\bar{P}_2}{s^2})$, and $\bar{P}_0 = \lim_{s \rightarrow 0} (\bar{P}(s) - \frac{\bar{P}_2}{s^2} - \frac{\bar{P}_1}{s})$.

Theorem 15. Given a graph \mathcal{G} with incidence matrix \mathcal{Q} , satisfying Assumption 5 and modelling the communication links among multiple strictly proper NI agents $\hat{P}_i(s)$ (allowing possible poles at the origin) which are appropriately extended to $P_i(s)$ as in Fig. 3, robust output feedback consensus is achieved via the feedback control law in (4) or (5) under any external disturbances $w_1 \in \text{Im}_{\mathcal{L}_2}(\mathcal{Q} \otimes I_m)$ and $w_2 \in \mathcal{L}_2$ as well as under any model uncertainty $\Delta_i(s)$, $i \in \{1, \dots, n\}$ satisfying Assumption 6 if and only if the necessary and sufficient conditions in Lemma 14 are satisfied for $[\bar{P}(s), \bar{P}_s(s)]$.

Proof. Lemma 14 guarantees the internal stability of $[\bar{P}(s), \bar{P}_s(s)]$. Nominal output consensus is then achieved without considering the external disturbances w_1 and w_2 via internal stability as discussed in the proof of Theorem 10. Then, similar analysis as in the proof of Theorem 10 guarantees robustness against both external disturbances as well as additive SNI model uncertainty. \square

One could enquire whether the conditions in Lemma 14 simplify or not in some cases. The answer is positive as we present next.

Theorem 16. Given a graph \mathcal{G} with incidence matrix \mathcal{Q} , satisfying Assumption 5 and modelling the communication links among n_2 strictly proper NI agents $\hat{P}_i(s)$ (allowing possible poles at the origin) with double poles at the origin (i.e. no single pole at the origin) and n_1 (at least 1) agents without free body dynamics (i.e. without poles at the origin) in Fig. 3, a necessary and sufficient condition for robust output feedback consensus via the feedback control law in (4) or (5) under external disturbances $w_1 \in \text{Im}_{\mathcal{L}_2}(\mathcal{Q} \otimes I_m)$ and $w_2 \in \mathcal{L}_2$ and under any model uncertainty satisfying Assumption 6 is

$$J_{n_2}^T \mathcal{L}_{e,11} J_{n_2} < 0,$$

where $J_{n_2} \triangleq \text{diag}\{J_{2,i}\}_{i=1}^{n_2}$ with $J_{2,i}$ being full column rank matrices satisfying $J_{2,i} J_{2,i}^T = \lim_{s \rightarrow 0} s^2 P_i(s) \neq 0$ for n_2 agents and $\mathcal{L}_{e,11} \in \mathbb{R}^{n_2 m \times n_2 m}$ is part of the weighted Laplacian matrix constructed as follows:

$$\mathcal{L}_e = \begin{bmatrix} \mathcal{L}_{e,11} & \mathcal{L}_{e,12} \\ \mathcal{L}_{e,12}^T & \mathcal{L}_{e,22} \end{bmatrix} = \chi(\mathcal{Q} \otimes I_m) \text{diag}\{P_{s,j}(0)\}_{j=1}^l (\mathcal{Q}^T \otimes I_m) \chi^T$$

where χ is a permutation matrix such that

$$\chi \lim_{s \rightarrow 0} s^2 \text{diag}\{P_i(s)\}_{i=1}^{n_2} \chi^T = \begin{bmatrix} \text{diag}\{P_{2,i}\}_{i=1}^{n_2} & 0 \\ 0 & 0_{mn_1 \times mn_1} \end{bmatrix}$$

and $P_{s,j}(s) \forall j \in \{1, \dots, l\}$ are SNI compensators.

Proof. It can be seen that this case corresponds to $\bar{P}_2 \neq 0$, $\bar{P}_1 = 0$ and $\text{Ker}(\bar{P}_2) \subseteq \text{Ker}(\bar{P}_0^T)$ in Theorem 15. The necessary and sufficient

condition in this case is $\bar{J}^T \bar{P}_s(0) \bar{J} < 0$ due to Lemma 14, where $\bar{P}_2 = \bar{J} \bar{J}^T$ with \bar{J} being full column rank. Since

$$\begin{aligned} \bar{P}_2 &= \lim_{s \rightarrow 0} s^2 \bar{P}(s) \\ &= \lim_{s \rightarrow 0} (\mathcal{Q}^T \otimes I_m) s^2 \text{diag}\{P_i(s)\} (\mathcal{Q} \otimes I_m) \\ &= (\mathcal{Q}^T \otimes I_m) \chi^T \begin{bmatrix} \text{diag}\{P_{2,i}\} & 0 \\ 0 & 0_{mn_1 \times mn_1} \end{bmatrix} \chi (\mathcal{Q} \otimes I_m) \\ &= (\mathcal{Q}^T \otimes I_m) \chi^T \underbrace{\begin{bmatrix} \text{diag}\{J_{2,i}\} \\ 0 \end{bmatrix}}_{J_P} \underbrace{\begin{bmatrix} \text{diag}\{J_{2,i}^T\} & 0 \end{bmatrix}}_{J_P^T} \chi (\mathcal{Q} \otimes I_m) \\ &= \bar{J} \bar{J}^T, \end{aligned}$$

where χ is a permutation matrix which also has a representation of $\chi = (\Upsilon \otimes I_m)$ with Υ also being a permutation matrix, $P_{2,i} = \lim_{s \rightarrow 0} s^2 P_i(s) \neq 0$ for the n_2 agents $P_s(s)$ that have a double pole at the origin and $J_{2,i} J_{2,i}^T = P_{2,i}$ where $J_{2,i}$ is full column rank matrix. It can be seen that J_P has at least m zero rows due to the existence of at least one $m \times m$ agent without free body dynamics. Thus

$$\begin{aligned} \bar{J} &= (\mathcal{Q}^T \otimes I_m) \chi^T J_P = (\mathcal{Q}^T \Upsilon^T \otimes I_m) J_P \\ &= \left(\begin{bmatrix} \hat{\mathcal{Q}}_1^T & \hat{\mathcal{Q}}_2^T \end{bmatrix} \otimes I_m \right) J_P = \begin{bmatrix} \hat{\mathcal{Q}}_1^T \otimes I_m \\ \hat{\mathcal{Q}}_2^T \otimes I_m \end{bmatrix} \text{diag}\{J_{2,i}\}, \end{aligned}$$

where $\hat{\mathcal{Q}}_1, \hat{\mathcal{Q}}_2$ are row submatrices of $\Upsilon \mathcal{Q} = \begin{bmatrix} \hat{\mathcal{Q}}_1 \\ \hat{\mathcal{Q}}_2 \end{bmatrix}$. According to Assumption 5, the rank property of \mathcal{Q} and the invertibility of permutation matrix Υ , the removal of $\hat{\mathcal{Q}}_2 \otimes I_m$ yields a full column rank of $\hat{\mathcal{Q}}_1^T$ and thus $\text{rank}(\bar{J}) = \text{rank}(\text{diag}\{J_{2,i}\})$, which also implies that \bar{J} is full column rank due to the full column rank matrix $J_{2,i}$. Then, with the notation of $J_{n_2} \triangleq \text{diag}\{J_{2,i}\}$,

$$\begin{aligned} \bar{J}^T \bar{P}_s(0) \bar{J} &< 0 \\ \Leftrightarrow \begin{bmatrix} J_{n_2}^T & 0 \end{bmatrix} \chi (\mathcal{Q} \otimes I_m) \text{diag}\{P_{s,j}(0)\} (\mathcal{Q}^T \otimes I_m) \chi^T \begin{bmatrix} J_{n_2} \\ 0 \end{bmatrix} &< 0 \\ \Leftrightarrow \begin{bmatrix} J_{n_2}^T & 0 \end{bmatrix} \mathcal{L}_e \begin{bmatrix} J_{n_2} \\ 0 \end{bmatrix} = \begin{bmatrix} J_{n_2}^T & 0 \end{bmatrix} \begin{bmatrix} \mathcal{L}_{e,11} & \mathcal{L}_{e,12} \\ \mathcal{L}_{e,12}^T & \mathcal{L}_{e,22} \end{bmatrix} \begin{bmatrix} J_{n_2} \\ 0 \end{bmatrix} &< 0 \\ \Leftrightarrow J_{n_2}^T \mathcal{L}_{e,11} J_{n_2} &< 0. \end{aligned}$$

Similar steps as in the proof of Theorem 10 then shows that robustness against external disturbances as well as additive SNI model uncertainty also holds here. \square

The above theorem gives a necessary and sufficient condition for robust output feedback consensus directly on the graph information and on the D.C. gain of the SNI controllers. The edge weights (i.e. the D.C. gains of the SNI controllers that are connected with agents that have a double pole at the origin) are important in determining the sign definiteness of $J_{n_2}^T \mathcal{L}_{e,11} J_{n_2}$, in other words, the internal stability of the networked system. The D.C. gains of the remaining SNI controllers are irrelevant and can be freely chosen as long as they are nonsingular.

Remark 17. When the SNI controllers are homogeneous, the consensus law (4) simplifies to $\mathbf{u} = (\mathcal{Q} \otimes I_m) (I_n \otimes P_s(s)) (\mathcal{Q}^T \otimes I_m) \mathbf{y} = \mathcal{L}_n \otimes P_s(s) \mathbf{y}$, or in a distributed manner, $\mathbf{u}_i = P_s(s) \sum_{k=1}^n a_{ik} (\mathbf{y}_i - \mathbf{y}_k)$. It can be seen that this captures the main result of Wang, Lanzon, and Petersen (2014) in the homogeneous plant case but also generalises the results to the heterogeneous plant case. In the case of heterogeneous SNI controllers, the controller is given by

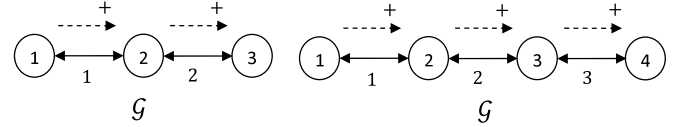

Fig. 5. Graph for 3 and 4 NI systems.

$\mathbf{u} = (\mathcal{Q} \otimes I_m) \bar{P}_s(s) (\mathcal{Q}^T \otimes I_m) \mathbf{y} = \bar{\mathcal{L}}_e(s) \mathbf{y}$, which can be interpreted as a weighted graph \mathcal{G} with the edges weighted by the controller transfer functions $P_{s,j}(s)$, $j = 1, \dots, l$, or in a distributed manner: $\mathbf{u}_i = \sum_{k=1}^n a_{ik} P_{s,j}(s) (\mathbf{y}_i - \mathbf{y}_k)$, where j is the edge connected vertex i and k . The above facts give a nice intuitive interpretation and explain why we adopt the incidence matrix for the distributed property rather than the Laplacian matrix as indicated earlier.

2.3. Illustrative examples

Two cases are given to illustrate the main results of this paper, Theorems 10 and 15 respectively. The first case considers multiple NI systems without poles at the origin but allowing the plants to be biproper, while the second case is to show the more general case by including NI systems with poles at the origin but under the requirement of strictly proper plants.

2.3.1. 2 lightly damped and 1 undamped flexible structures

Fig. 2 in Lanzon and Petersen (2008) depicts a flexible structure that can also be studied in this paper. The dynamics can be expressed as: $M_i \ddot{\mathbf{x}}_i + C_i \dot{\mathbf{x}}_i + K_i \mathbf{x}_i = \mathbf{u}_i, \mathbf{y}_i = \mathbf{x}_i, i \in \{1, \dots, 3\}$, where $\mathbf{x}_i = \begin{bmatrix} x_{i,1} \\ x_{i,2} \end{bmatrix}, \mathbf{u}_i = \begin{bmatrix} u_{i,1} \\ u_{i,2} \end{bmatrix}, M_i = \begin{bmatrix} m_{i,1} & 0 \\ 0 & m_{i,2} \end{bmatrix}, C_i = \begin{bmatrix} c_{i,1} + c_i & -c_i \\ -c_i & c_{i,2} + c_i \end{bmatrix}, K_i = \begin{bmatrix} k_{i,1} + k_i & -k_i \\ -k_i & k_{i,2} + k_i \end{bmatrix}$. The undamped flexible structure is given by letting the damped term $C_i = 0$. The parameters are given as follows:

- System 1: $k_1 = k_{1,1} = k_{1,2} = 0.5, c_1 = c_{1,1} = c_{1,2} = 0.2, m_{1,1} = m_{1,2} = 1$ with initial condition of $[0.5 \ 0.1 \ 1 \ 0.2]^T$
- System 2: $k_2 = k_{2,1} = k_{2,2} = 1, c_2 = c_{2,1} = c_{2,2} = 0.1, m_{2,1} = 1, m_{2,2} = 0.5$ with initial condition of $[1 \ 0.1 \ 1.5 \ 0.2]^T$;
- System 3: $k_3 = k_{3,1} = k_{3,2} = 1, c_3 = c_{3,1} = c_{3,2} = 0, m_{3,1} = 1, m_{3,2} = 0.5$ with initial condition of $[1.5 \ 0.1 \ 2 \ 0.2]^T$.

The communication topology is given in Fig. 5 and thus $\mathcal{Q} = \begin{bmatrix} 1 & 0 \\ -1 & 1 \\ 0 & -1 \end{bmatrix}$ and $\mathcal{L}_n = \begin{bmatrix} 1 & -1 & 0 \\ -1 & 2 & -1 \\ 0 & -1 & 1 \end{bmatrix}$. It can easily be seen that $\max_{i=1}^3 \bar{\lambda}(P_i(0)) = 2 > 0$. Both the SNI controllers are chosen as $\frac{1}{s+8}$ with an initial condition of -1 such that $\bar{\lambda}(P_i(0)) \bar{\lambda}(P_{s,j}(0)) = 2 * \frac{1}{8} = \frac{1}{4} < \frac{1}{3} = \frac{1}{\bar{\lambda}(\mathcal{L}_n)} \forall i \in \{1, \dots, n\}, j \in \{1, \dots, l\}$. In addition, $\forall i \in \{1, \dots, n\}, j \in \{1, \dots, l\}, P_i(\infty) P_{s,j}(\infty) = 0, P_{s,j}(\infty) = 0$, which all satisfy the suppositions of Theorem 10. First, without disturbances and model uncertainty, nominal output feedback consensus is achieved via the control law in (4) or (5) as shown in the top two figures of Fig. 6. Then introducing additive SNI model uncertainty, for example given by $\frac{1}{s+4}$ as well as \mathcal{L}_2 external disturbances, robust output feedback consensus is also achieved as shown in the bottom two figures of Fig. 6.

2.3.2. 1 single integrator, 1 double integrator, 1 undamped and 1 lightly damped flexible structure

In order to illustrate Theorem 15, systems with free body dynamics will be included in this example. Therefore, a complicated case containing 1 single integrator, 1 double integrator, 1 MIMO undamped and 1 MIMO lightly damped flexible structure is considered in this example. For consistency of dimension, the single integrator and the double integrator are extended as follows:

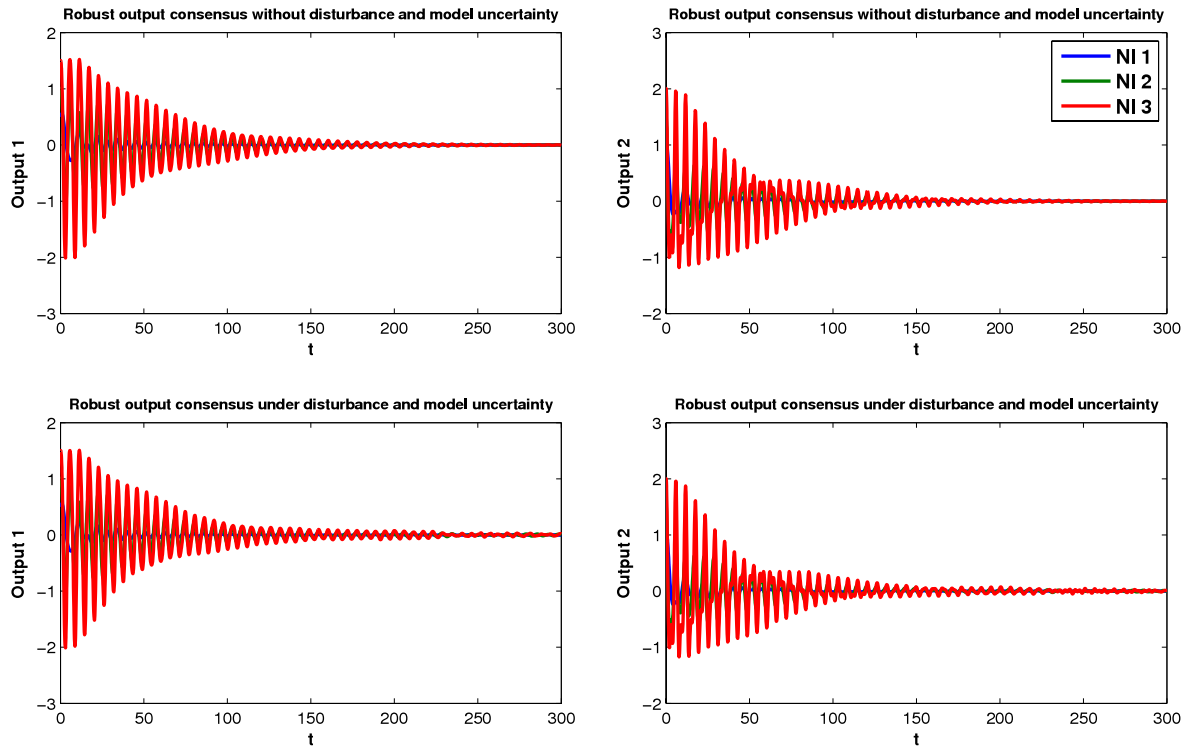

Fig. 6. Robust output consensus of heterogeneous NI systems.

$\text{diag}\{\frac{1}{s}, 0\}$ and $\text{diag}\{0, \frac{1}{s^2}\}$, which also means that the output of single integrator will be coordinated with first outputs of both the undamped and the lightly damped flexible structures, while the output of double integrator will be coordinated with second outputs of both the undamped and the lightly damped flexible structures. The parameters of all NI systems are as follows:

System 1: $\frac{1}{s^2}$ with initial condition of $[1 \ 0.1]^T$;

System 2: $\frac{1}{s}$ with initial condition of 2;

System 3: $k_3 = k_{3,1} = k_{3,2} = 1, c_3 = c_{3,1} = c_{3,2} = 0, m_{3,1} = 1, m_{3,2} = 0.5$ with initial condition of $[3 \ 0.1 \ 3 \ 0.2]^T$;

System 4: $k_4 = k_{4,1} = k_{4,2} = 1, c_4 = c_{4,1} = c_{4,2} = 0.1, m_{4,1} = 1, m_{4,2} = 0.5$ with initial condition of $[4 \ 0.1 \ 4 \ 0.2]^T$.

The communication topology is given in Fig. 5 and thus $\mathcal{Q} = \begin{bmatrix} 1 & 0 & 0 \\ -1 & 1 & 0 \\ 0 & -1 & 1 \\ 0 & 0 & -1 \end{bmatrix}$ and $\mathcal{L}_n = \begin{bmatrix} 1 & -1 & 0 & 0 \\ -1 & 2 & -1 & 0 \\ 0 & -1 & 2 & 1 \\ 0 & 0 & -1 & 1 \end{bmatrix}$. All three SNI

controllers are chosen as $-\frac{s+1}{s+2}$ with an initial condition of 0.1. Through the calculation process discussed earlier in Section 2.2, the inequality condition (9) can be verified as $\det(I + \tilde{N}_f \tilde{P}_0 \tilde{N}_f + \tilde{N}_f \tilde{P}_1 J (J^T J)^{-2} J^T \tilde{P}_1^T \tilde{N}_f) = 3.7813 \neq 0$, which indicates internal stability of $[\tilde{P}(s), \tilde{P}_s(s)]$. First, without disturbances and model uncertainty, nominal output feedback consensus is achieved via the output feedback control law (4) or (5) as shown in the top two figures of Fig. 7. If the same external disturbances and model uncertainty as in Section 2.3.1 are inserted, robust output feedback consensus is also achieved via output feedback control law (4) or (5) as shown in the bottom two figures of Fig. 7. The left two figures of Fig. 7 indicate the output of the single integrator (System 2) is coordinated with the first output of undamped flexible structure (System 3) and the first output of lightly damped flexible structure (System 4) even under external disturbances and model uncertainty. Similarly, the right two figures of Fig. 7 indicate the output of the double integrator (System 1) is coordinated with the second output of undamped flexible structure (System 3) and

the second output of the lightly damped flexible structure (System 4) even under external disturbances and model uncertainty.

3. Extension to robust cooperative control

In this section, we exploit the proposed consensus results for cooperative tracking to obtain a robust cooperative control framework for multiple NI systems. A famous rendezvous problem is presented to show the effectiveness of the proposed framework. Other cooperative problems can be obtained analogously by adapting the proposed consensus algorithm. The objective of cooperative tracking is to achieve the convergence of all agents' outputs to a pre-defined constant reference while the objective of rendezvous is its direct application for all the agents to converge to a pre-defined point. To solve this problem, let us first define a matrix \mathcal{B} to express the connections between agents following Ref. Ni and Cheng (2010): $\mathcal{B} = \text{diag}\{b_i\}$, where $b_i = 1$ if agent i

is connected with a reference, otherwise $b_i = 0$. From $\mathcal{L}_n = \mathcal{Q}\mathcal{Q}^T$, we can similarly decompose \mathcal{B} as $\mathcal{Q}_b \mathcal{Q}_b^T$ where \mathcal{Q}_b is full column rank matrix. It can be seen that \mathcal{Q}_b is defined analogously as \mathcal{Q} by $\mathcal{Q}_b = [\beta_1 \ \dots \ \beta_{l_b}]$, where l_b is the number of agents connected to the reference and $\beta_{j_b} \ \forall j_b \in \{1, \dots, l_b\}$ is a vector in \mathbb{R}^n with the i th element being a 1 if agent i is connected to the reference. Then, the incidence matrix \mathcal{Q} can be augmented with \mathcal{Q}_b to give $[\mathcal{Q} \ \mathcal{Q}_b]$ which also shows the additional links from the reference to agents. The augmented matrix $[\mathcal{Q} \ \mathcal{Q}_b]$ still guarantees that $([\mathcal{Q} \ \mathcal{Q}_b]^T \otimes I_m) \tilde{P}(s) ([\mathcal{Q} \ \mathcal{Q}_b] \otimes I_m)$ is NI in Fig. 2 and thus NI system theory can be applied to the robust output feedback consensus problem as shown in the previous section. The main result of this section is given next.

Theorem 18. Given a graph \mathcal{G} with incidence matrix \mathcal{Q} , satisfying Assumption 5 and modelling the communication links among multiple NI agents $\tilde{P}_i(s)$ which are appropriately extended to $P_i(s)$ as

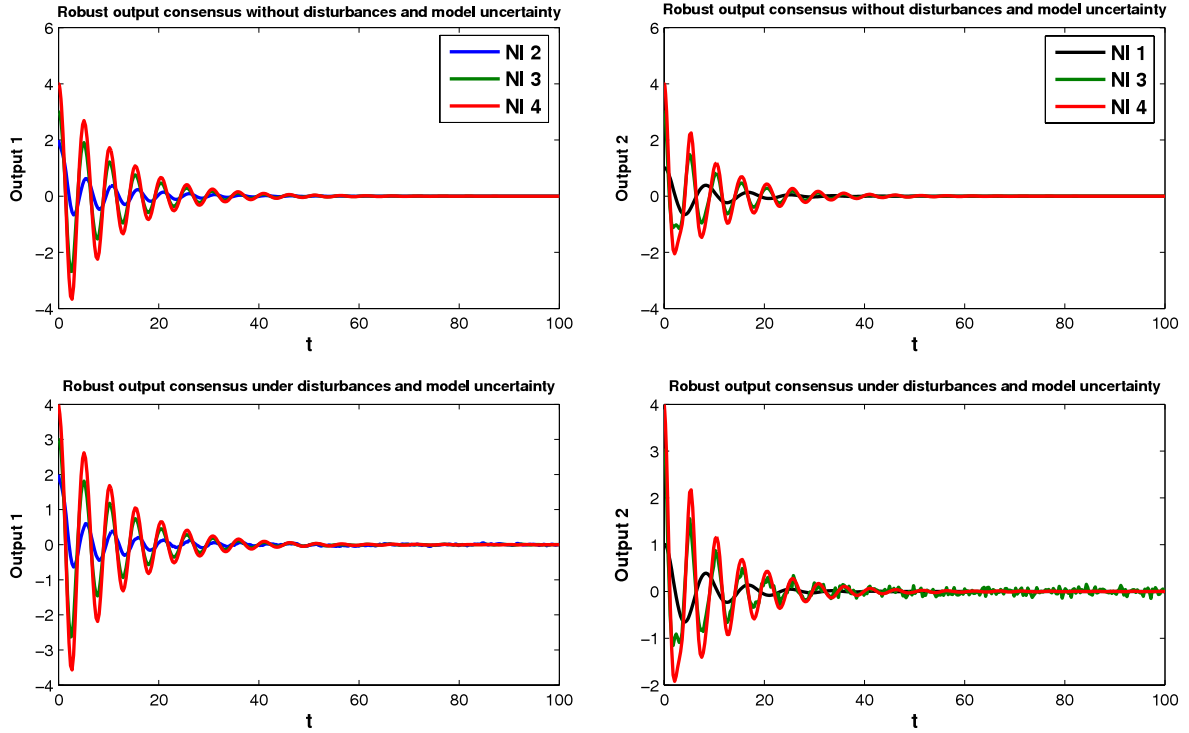

Fig. 7. Robust output consensus of heterogeneous NI systems.

in Fig. 3, robust cooperative output tracking of a constant reference \mathbf{r} is achieved via the output feedback control law

$$\mathbf{u}_{ct} = \left(\begin{bmatrix} \mathcal{Q} & \mathcal{Q}_b \end{bmatrix} \otimes I_m \right) \bar{P}_s(s) \left(\begin{bmatrix} \mathcal{Q} & \mathcal{Q}_b \end{bmatrix}^T \otimes I_m \right) (\mathbf{y} - \mathbf{1}_n \otimes \mathbf{r}), \quad (10)$$

or in a distributed manner $\forall i \in \{1, \dots, n\}$ by

$$\mathbf{u}_i^{ct} = \sum_{k=1}^n a_{ik} P_{s,j}(s) (\mathbf{y}_i - \mathbf{y}_k) + b_i P_{s,j_b}(s) (\mathbf{y}_i - \mathbf{r}) \quad (11)$$

where $j \in \{1, \dots, l\}$ corresponds to the edge number connecting agents i and k , and $j_b \in \{1, \dots, l_b\}$ corresponds to the link number connecting reference \mathbf{r} to agent i , under any external disturbances $w_1 \in \mathcal{L}_2$ and $w_2 \in \mathcal{L}_2$ as well as under any model uncertainty satisfying Assumption 6 if and only if the relevant conditions in Theorem 10 or Lemma 14 are satisfied for $[\bar{P}(s), \bar{P}_s(s)]$.

Proof. Given a constant reference \mathbf{r} , the matrix $\begin{bmatrix} \mathcal{Q} & \mathcal{Q}_b \end{bmatrix}^T$ has the property that

$$\bar{\mathbf{y}} = \left(\begin{bmatrix} \mathcal{Q}^T \\ \mathcal{Q}_b^T \end{bmatrix} \otimes I_m \right) (\mathbf{y} - \mathbf{1}_n \otimes \mathbf{r}) = \begin{bmatrix} (\mathcal{Q}^T \otimes I_m) \mathbf{y} \\ (\mathcal{Q}_b^T \otimes I_m) (\mathbf{y} - \mathbf{1}_n \otimes \mathbf{r}) \end{bmatrix}$$

since $(\mathcal{Q}^T \otimes I_m)(\mathbf{1}_n \otimes \mathbf{r}) = \mathbf{0}$ due to the null space property of incidence matrix in Section 1. Therefore, internal stability guaranteed by Theorem 10 or Lemma 14 leads to $\bar{\mathbf{y}} \rightarrow \mathbf{0}$, which is equivalent to $\mathbf{y}_i \rightarrow \mathbf{y}_k \forall i \neq k \in \{1, \dots, n\}$ due to $(\mathcal{Q}^T \otimes I_m) \mathbf{y} \rightarrow \mathbf{0}$ and $\mathbf{y}_{j_b} \rightarrow \mathbf{r} \forall j_b \in \{1, \dots, l_b\}$ due to $(\mathcal{Q}_b^T \otimes I_m) (\mathbf{y} - \mathbf{1}_n \otimes \mathbf{r}) \rightarrow \mathbf{0}$. This then implies that robust cooperative output tracking is achieved, i.e., $\mathbf{y}_i = \mathbf{y}_k = \mathbf{r} \forall i \in \{1, \dots, n\}$ and $k \in \{1, \dots, n\}/\{i\}$ via arguments like those in the proof of Theorem 10. \square

3.1. 3D rendezvous missions

A direct application of cooperative tracking, robust rendezvous is shown in a 3D scenario. We use plants composed of $\frac{1}{s^2} I_3, \frac{1}{s} I_3, \frac{1}{s} I_3$ with the initial conditions in 3 axis being

$[1 \ 0.1 \ 1 \ 1 \ 1 \ -0.1]^T, [2 \ 0.2 \ 2 \ -1 \ 2 \ -0.2]^T$ and $[0.3 \ 0.5 \ 0.8]^T$ respectively. The pre-defined rendezvous point is $[1 \ -0.5 \ 0]^T$. The graph is exactly the same as Fig. 5 and the reference only sends information to agent 3, which gives $\mathcal{B} = \text{diag}\{0, 0, 1\}$ and $\mathcal{Q}_b = [0 \ 0 \ 1]^T$. Comparing with the cases in Theorem 15, it can be seen that this is the case when $P_1 \neq 0$ and $P_2 \neq 0$. Therefore, Lemma 14 is used and it is easy to see that $N_f \leq 0$ and $\det(I + \tilde{N}_f P_0 \tilde{N}_f + \tilde{N}_f P_1 J (J^T J)^{-2} J^T P_1^T \tilde{N}_f) = 1 \neq 0$. Robust rendezvous is then guaranteed via the cooperative tracking controller (10) or (11) in Theorem 18. It can be seen from Fig. 8 that the cooperative tracking control law (10) or (11) is able to drive the agents from the initial positions marked as diamonds to the final rendezvous point even under the same external disturbances and model uncertainty as in Section 2.3.1.

4. Conclusion remarks

Robust cooperative control for heterogeneous NI systems is proposed via NI systems theory. Robust output feedback consensus against external disturbances and NI model uncertainty is studied first and then the results are exploited for cooperative tracking to derive a cooperative control framework. The key contributions of this paper can be summarised as follows: (1) cooperative control which is robust to exogenous disturbances and SNI model uncertainty for general heterogeneous network of MIMO NI systems under any undirected and connected graph; (2) only exploiting output feedback information in contrast to full state information commonly used in the literature; (3) providing a whole class of cooperative control laws, i.e. SNI controllers, that can be tuned for performance and characterising conditions that can be easily checked for robust output feedback consensus; (4) showing how consensus and cooperative control problems can exploit powerful internal stability and robust stability results available in the literature.

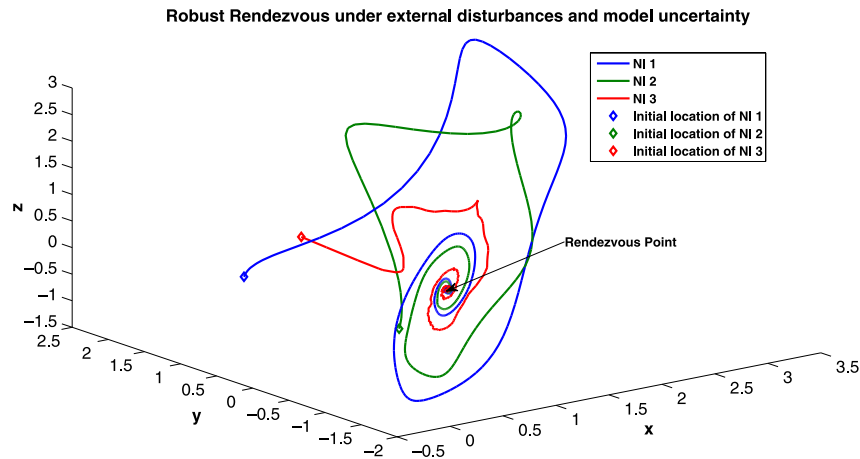

Fig. 8. 3D robust rendezvous of heterogeneous NI systems.

Acknowledgments

The financial support of the Engineering and Physical Sciences Research Council, the UK Department for Business, Innovation and Skills, the Australian Research Council, the Excellent Young Scholars Research Fund of Beijing Institute of Technology as well as the Beijing Institute of Technology Research Fund Program for Young Scholars is gratefully acknowledged.

References

- Bapat, R.B. (2010). *Graph and matrices*. Springer-Verlag London, jointly published with Hindustan Book Agency (HBA), New Delhi, India.
- Cai, C. H., & Hagen, G. (2010). Stability analysis for a string of coupled stable subsystems with negative imaginary frequency response. *IEEE Transactions on Automatic Control*, *55*, 1958–1963.
- Ferrante, A., Lanzon, A., & Ntogramatzidis, L. (2014). Foundations of not necessarily rational negative imaginary systems theory: Relations between classes of negative imaginary and positive real systems. *IEEE Transactions on Automatic Control*, (submitted for publication) See also technical report at: [arXiv:1412.5709v1](https://arxiv.org/abs/1412.5709v1).
- Ferrante, A., & Ntogramatzidis, L. (2013). Some new results in the theory of negative imaginary systems with symmetric transfer matrix function. *Automatica*, *49*, 2138–2144.
- Golub, G. H., & Van Loan, C. F. (2012). *Matrix computations*. Baltimore, MD, USA: JHU Press.
- Grone, R., & Merris, R. (1994). The Laplacian spectrum of a graph II. *SIAM Journal on Discrete Mathematics*, *22*, 221–229.
- Lanzon, A., & Petersen, I. R. (2008). Stability robustness of a feedback interconnection of systems with negative imaginary frequency response. *IEEE Transactions on Automatic Control*, *53*, 1042–1046.
- Li, Z. K., Duan, Z. S., Chen, G. R., & Huang, L. (2010). Consensus of multiagent systems and synchronization of complex networks: A unified view point. *IEEE Transactions on Circuits and Systems*, *57*, 213–224.
- Mabrok, M. A., Kallapur, A. G., Petersen, I. R., & Lanzon, A. (2014a). Generalizing negative imaginary systems theory to include free body dynamics: Control of highly resonant structures with free body motion. *IEEE Transactions on Automatic Control*, *59*, 2692–2707.
- Mabrok, M. A., Kallapur, A. G., Petersen, I. R., & Lanzon, A. (2014b). Spectral conditions for negative imaginary systems with applications to nanopositioning. *IEEE/ASME Transactions on Mechatronics*, *19*, 895–903.
- Ni, W., & Cheng, D. Z. (2010). Leader-following consensus of multi-agent systems under fixed and switching topologies. *Systems & Control Letters*, *59*, 209–217.
- Opmeer, M. R. (2011). Infinite-dimensional negative imaginary systems. *IEEE Transactions on Automatic Control*, *56*, 2973–2976.
- Petersen, I. R., & Lanzon, A. (2010). Feedback control of negative-imaginary systems. *IEEE Control Systems Magazine*, *30*, 54–72.
- Ren, W., & Beard, R. W. (2008). *Communications and control engineering serie, Distributed consensus in multi-vehicle cooperative control*. London: Springer-Verlag.
- Song, Z., Lanzon, A., Patra, S., & Petersen, I. R. (2012a). A negative-imaginary lemma without minimality assumptions and robust state-feedback synthesis for uncertain negative-imaginary systems. *Systems & Control Letters*, *61*, 1269–1276.
- Song, Z., Lanzon, A., Patra, S., & Petersen, I. R. (2012b). Robust performance analysis for uncertain negative-imaginary systems. *International Journal of Robust and Nonlinear Control*, *22*(3), 262–281.
- Su, Y. F., & Huang, J. (2013). Cooperative robust output regulation of a class of heterogeneous linear uncertain multi-agent systems. *International Journal of Robust and Nonlinear Control*, <http://dx.doi.org/10.1002/rnc.3027>.
- Wang, J.N., Lanzon, A., & Petersen, I.R. (2014). A robust output feedback consensus protocol for networked negative-imaginary systems. In *2014 IFAC world congress, Cape Town, South Africa, August*.
- Wang, J. N., Lanzon, A., & Petersen, I. R. (2015). Robust output feedback consensus for networked negative-imaginary systems. *IEEE Transactions on Automatic Control*, <http://dx.doi.org/10.1109/TAC.2015.2395472>, in press.
- Xiong, J. L., Petersen, I. R., & Lanzon, A. (2010). A negative imaginary lemma and the stability of interconnections of linear negative imaginary systems. *IEEE Transactions on Automatic Control*, *55*, 2342–2347.
- Zhou, K., Doyle, J. C., & Glover, K. (1996). *Robust and optimal control*. NJ, Englewood Cliffs: Prentice-Hall.
- Zhu, L. J., & Chen, Z. Y. (2014). Robust homogenization and consensus of nonlinear multi-agent systems. *Systems & Control Letters*, *65*, 50–55.



Jianan Wang is currently an Associate Professor in the School of Aerospace Engineering at Beijing Institute of Technology, Beijing, China. He received his B.S. and M.S. in Control Science and Engineering from the Beijing Jiaotong University and Beijing Institute of Technology, Beijing, China, in 2004 and 2007, respectively. He received his Ph.D. in Aerospace Engineering at Mississippi State University, Starkville, MS, USA in 2011. His research interests include cooperative control of multiple dynamic systems, UAV formation control, obstacle/collision avoidance, trustworthy networked system, and estimation of sensor networks. He is also a senior member of American Institute of Aeronautics and Astronautics (AIAA).



Alexander Lanzon holds the Chair in Control Engineering at the University of Manchester. He received his Ph.D. degree in Control Theory from the University of Cambridge in 2000, his M.Phil. degree in Control Engineering also from the University of Cambridge in 1997 and his B.Eng.(Hons) degree in Electrical and Electronic Engineering from the University of Malta in 1995. Before joining the University of Manchester in 2006, Alexander held academic positions at Georgia Institute of Technology and the Australian National University. Dr Lanzon also earlier worked in industry at ST-Microelectronics Ltd., Yaskawa Denki (Tokyo) Ltd. and National ICT Australia Ltd. Prof. Lanzon is an Associate Editor of the *IEEE Transactions on Automatic Control*, a Subject Editor of the *International Journal of Robust and Nonlinear Control*, and a Fellow of the Institute of Mathematics and its Applications, the Institute of Measurement and Control and the Institution of Engineering and Technology.



Ian R. Petersen received the Ph.D. degree in Electrical Engineering from the University of Rochester, Rochester, NY, USA in 1984. From 1983 to 1985, he was a Postdoctoral Fellow at the Australian National University, Canberra. In 1985 he joined UNSW Canberra where he is currently Scientia Professor and an Australian Research Council Laureate Fellow in the School of Engineering and Information Technology. He is an Editor for *Automatica*. His main research interests are in robust control theory, quantum control theory and stochastic control theory. He is a Fellow of IFAC and the Australian Academy of Science. He is an Associate Editor for the *IEEE Transactions on Control Systems Technology*.